

E346+ —

E346V+ —



TOOL PRESETTER

GREAT VERSATILITY MAKES A GREAT PRESETTER MACHINE

NATURAL GRANITE, when used as a construction material, is ideal as it has unique physical and mechanical characteristics:

- THERMAL AND DIMENSIONAL STABILITY
- HARDNESS
- WEAR RESISTANCE
- WORKING PRECISION
- RESISTANT TO ACIDS, AMAGNETIC, ELECTRIC INSULATOR and STAINLESS

Granite is a natural material with one of the lowest thermal expansion coefficients in the world, an important peculiarity when it comes to measurement: for this reason, E346+ and E346V+ presetter machines are equipped with a natural granite base and column.



The oversized structure is synonymous of **precision, stability and reliability**

The E346+ and E346V+ structure is oversized when compared to the E346 model: in fact, it guarantees greater accuracy of measurements, better dimensional stability and excellent reliability in terms of measurement repeatability.

Moreover, the choice of having an oversized structure has made it possible to insert more advanced and reliable electronics, increasing performance without sacrificing the simplicity and ease of use of the machine.

*Pikes Peak is the highest summit of the southern Front Range of the Rocky Mountains, in North America. 4,302 meters high, it is located in the Pike National Forest.
It's composed of a characteristic pink GRANITE, due to a large amount of potassium feldspar. The mountain was born 1.05 billion years ago.*



Interchangeable rotating spindle: why limit yourself to using an adapter?

All the spindle-holders are totally interchangeable (ISO/BT/HSK/polygonal taper...etc): the coupling error is drastically reduced without the use of adapters, making the measurement more accurate.

How is it possible to guarantee the interchangeability of the spindle holders? Following strict construction and testing procedures, the result is guaranteed: the run-out error is less than 2 μm .

The spindle body with double ball bearing cage allows perfect coupling.

Repeatability is within everyone's reach. It's your choice.

Rapid and fine adjustment.
Simplicity rules

"Time is money" that's the word. So, why waste time?

Frame your tool quickly with rapid adjustment and collimate it with fine adjustment.

The ergonomic handle placed on the column helps you in this operation and the two fine adjustment knobs will make collimation quick and easy.

Do you need more security? Lock the spindle rotation with the mechanical brake and the game is done.



TECHNOLOGY AT YOUR SERVICE

An **easy** and **complete** presetting experience

The **NEW** 15" vertical Touch Screen monitor is perfect for displaying tool data clearly and completely.

All of the machine functions are available in a single screen, simplifying your life and making your presetting experience fluid and simple.

The Elbo Controlli NIKKEN philosophy is to offer solutions that reduce the possibility of error by the operator, guiding him in his work.

Everything simple. Without complication.



Everything you **need** can be found here

Why complicate your life with complex and difficult software?

We at Elbo Controlli NIKKEN believe in ease of use and, with the **NEW** machine software, have achieved this goal. Easy. Intuitive. Without constraints.

The new software guarantees high performance, always respecting ease and intuitiveness: discover the presetting world from our point of view.

Seeing is believing.



The **power** of **TID** turns into reality

The technology and power of TID (Automatic Tool Identification System) is available on the E346+ and E346V+.

TID allows you to have a two-way communication between the presetter and machine CNC by sending tool data. Furthermore, it eliminates insertion errors safely and reliably.

TID is an advantageous solution for your workshop, without the additional costs associated to the purchase of RFID storage devices and the application of read/write hardware.

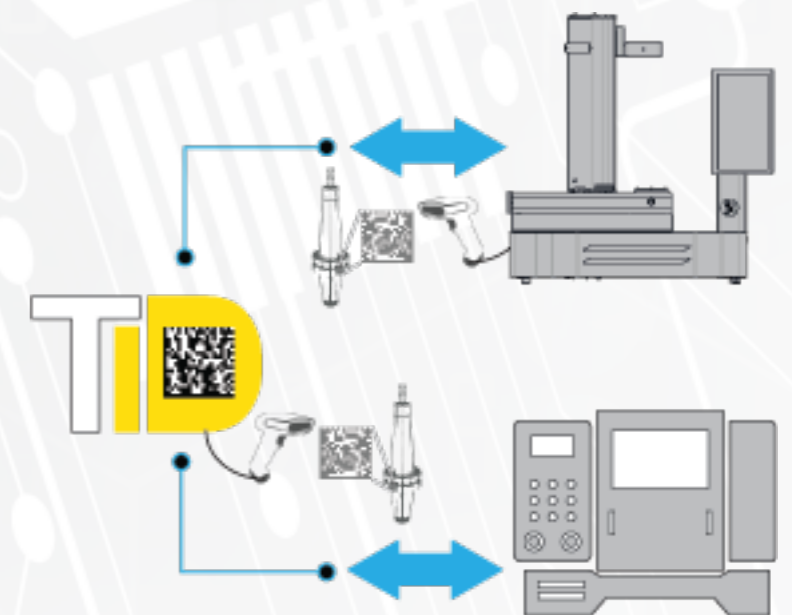

VACUUM CLAMPING SYSTEM

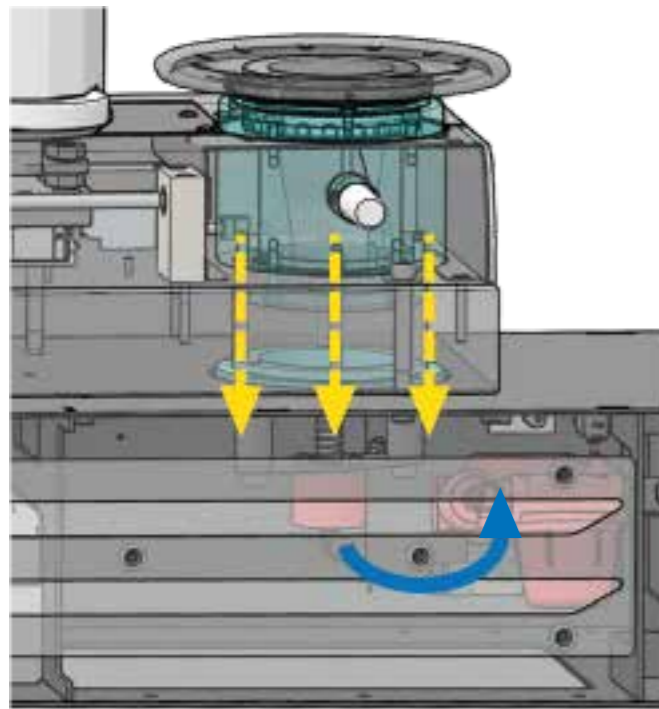

A clamping out of the ordinary

The VACUUM-based tool-holder clamping system allows greater measurement reliability.

The vacuum, generated inside the interchangeable rotating spindle holder, allows the tool holder to be adapted to a wide range of shanks without the need to change any adaptors.

The vacuum is created by the passage of compressed air into a duct, avoiding the use of a pump or any electro-mechanical moving parts.

No maintenance. No wear

Why not go for the maximum?

DETAIL MAKES THE DIFFERENCE

Machine stand

Integrate your presetting machine with a machine stand: sturdy and ergonomic, it facilitates the work.

The stand prevents damage to the ground part of the interchangeable spindles using the three lateral pots.

Tailor-made for your needs.

Dimension: 985 x 755 x 505 mm Weight: 65 Kg



Label printer

All the tool values are printed on a self-adhesive label.

Helpful and easy to use, insert the power supply and the USB to the presetter machine and the job is done.

COMPARISON

LEGEND: - not available ● available ○ optional

	E346+	E346V+
Measuring range: 360 mm Diameter, 460 mm Height	●	●
Natural granite base and column	●	●
Fine adjustment	●	●
Interchangeable spindle (ISO 40, ISO 50, HSK, VDI, polygonal taper...)	●	●
Manual mechanical spindle rotation brake	●	●
VACUUM clamping system	-	●
Double re-circulating ball bearing slides, lubricated for life	●	●
ELBO CONTROLLI NIKKEN camera system measuring range	6,4 x 6,4 mm	6,4 x 6,4 mm
ELBO CONTROLLI NIKKEN camera system measuring resolution	1 μm	1 μm
ELBO CONTROLLI NIKKEN camera system magnification	25 X	25 X
ELBO CONTROLLI NIKKEN certified optical scale (axes resolution = 1 μm)	●	●
Tool Data SIX (Td SIX) Post Processor universal generator	●	●
Tool recognition software via Datamatrix	●	●
Hardware for tool recognition via Datamatrix	○	○
Tool inspection function	●	●
CNC machine origin management	●	●
Tool list creation and/or single tool	●	●
Theoretical measurement and tolerance management	●	●
Printable tool set report	●	●
TFT 15" colour 16:9 vertical Touch Screen monitor	●	●
UBUNTU LINUX operating system	●	●
TID (Automatic Tool Identification System) ready	○	○
Label printer	○	○
Machine stand	○	○

"Details make perfection, and perfection is not a detail" Leonardo da Vinci

* The provided info relates to standard presetter machines

“
rock solid measurement
”

elbo controlli  **NIKKEN**

20821 MEDA (MB) - Italy - Via San Giorgio, 21
T. +39 0362 342745 - **F.** +39 0362 342741
www.elbocontrolli.com - info@elbocontrolli.it



Distributed by